

# FC-8T

## CEILING LOUDSPEAKER



### TECHNICAL DATA SHEET

#### PRODUCT SUMMARY

The IsoFlare™ FC-8T is a full bandwidth, high sensitivity ceiling loudspeaker designed for the ultimate in fidelity, coverage, and aesthetics.

The IsoFlare™ FC range is the new benchmark in point source technology for prestigious commercial environments. Decades of experience from acoustic and mechanical engineers specializing in this technology have honed existing skills complemented with the very latest in design & engineering techniques to bring IsoFlare™ to the premium commercial space in an integrated package.

Unlike most 'coax' offerings, the IsoFlare™ driver exhibits excellent harmonic alignment between HF and LF sources, the effect of which is to deliver accurate and natural reproduction with superb tonal balance.

Propagating a spherical wavefront, homogeneously aligned on all axes, the IsoFlare™ point source driver yields an even response throughout the listening area; a constant time delay over the entire frequency spectrum providing exceptional off-axis performance.

The FC-8T is designed for applications requiring a combination of premium sonic quality for music and speech reinforcement with exceptional reliability, in an architect/designer/installer friendly solution.

#### KEY FEATURES

- Patented toolless high travel secure-clamp mechanism for fast and trouble-free installation.
- Bezel-less grille - magnetically secured - removable logo. Allows for a single step painting process if necessary. No requirement for adapters to accommodate optional square grilles.
- Ferrofluid cooled titanium HF with neodymium magnet system.
- Multi-fiber treated paper cone; stiffness combined with controlled top end roll-off, for an accurate midrange.
- Fluted Surround Technology – Conventional driver surround profiles can reflect energy back down the cone causing coloration.
- Optimized smooth transition baffle (no sharp edges which cause diffraction).
- Full-bandwidth exceptionally low insertion loss 60 W 70/100 V transformer.
- High-current premium crossover components (Air Core Inductors & Polypropylene Capacitors).
- Easy Access Tap Rotary Selector Switch.
- Enhanced voicing presets available via AtlasIED Atmosphere platform.

#### APPLICATIONS

- Boardrooms & Corporate Offices
- Airports, Convention Centers, Hotels
- Casinos
- Houses of Worship
- Retail Outlets, Shopping Malls
- Museums
- Lounges / Bars
- Sports Facilities
- Health Clubs
- Performing Arts Centers
- Education Facilities
- Cruise Ships
- Courtrooms
- Multi-zone Foreground Music & Paging Systems

# FC-8T

## CEILING LOUDSPEAKER



### TECHNICAL DATA SHEET

#### AUDIO SPECIFICATIONS / PERFORMANCE

SYSTEM	FC-8T
Type	Two-Way, Full Range, Ceiling Loudspeaker (Blind Mount)
Frequency Range (-10 dB) <sup>1</sup>	44 Hz <sup>6</sup> –30 kHz
Frequency Response (+/-3 dB) <sup>1</sup>	59 Hz–25 kHz
System Sensitivity (1W @ 1m) <sup>2</sup>	92 dB
Nominal Coverage Angle (-6 dB)	90°
Directivity Index (dB) <sup>5</sup>	7.5

#### POWER HANDLING<sup>3</sup>

Average	90 W
Program	180 W
Peak	360 W
Recommended Amplifier Power	180 W @ 8 ohms
Nominal Impedance	8 ohms
Transformer Taps - via rotary selector switch 70/100V	60 W, 30 W, 15 W (7.5 W 70.7 V) & Low Z operation

#### RATED MAXIMUM SPL<sup>4</sup>

Average	112 dB
Peak	118 dB
With Max. Transformer Tap - Average	110 dB

#### TRANSDUCERS

Low Frequency	8" (200 mm) Bass/Mid, multi-fiber treated paper cone
High Frequency	1" (25 mm) titanium dome with neodymium magnet system, ferrofluid cooled

#### ENCLOSURE

Back can	Powder Coated Steel (Black)
Baffle	High Impact ABS UL-V0 (Black)
Grille	Steel, weather resistant coating (White)
Safety Features	Safety ring for load bearing safety bond
Clamping design	SafetyFirst™ with locking dog legs Min/Max Clamping Range - 0.33"–1.70" (8.38 mm–43.18 mm)
Cable Entry Options	Cable clamp & squeeze connector for conduit up to 0.87" (22 mm)
Input Connection	Removable locking Euroblock connector with screw terminals & loop through facility
Safety Agency Rating	UL1480A, UL2043, CE Suitable for use in air handling spaces per NFPA90 & NFPA70
Ingress Protection	IP44
Operating Temperature	-40°F to 140°F (-40° C to 60° C)
Environmental Testing	Salt Spray
Baffle Diameter	ø 12.75" (323.9 mm)
Back Can Diameter	ø 11.28" (286.5 mm)
Cutout Diameter	ø 12.91" (293.9 mm)
Mounting Depth	13.50" (343.0 mm)
Overall Depth	13.67" (347.1 mm)

# FC-8T

## CEILING LOUDSPEAKER



### TECHNICAL DATA SHEET

#### AUDIO SPECIFICATIONS / PERFORMANCE (CONTINUED)

Round Grille Length	ø 12.91" (341.9 mm)
Square Grille Length	12.91" (341.9 mm)
Included Accessories	C-Ring, tile-bridge kit, paint mask, cut-out template, round white grille
Optional Accessories	Plaster (mud) ring, round black grille, square white grille, square black grille, tile bridge kit
Packed Quantity	2
Shipping Dimensions (H x W x D)	16.2" x 37.4" x 22.1" (41 cm x 95 cm x 56 cm)
Net Weight (per unit)	17.2 lbs (7.8 kg)
Shipping Weight	52 lbs (23.6 kg)

Notes:

- 1 - Average over stated bandwidth, full space, IEC Baffle
- 2 - Unweighted pink noise input, measured at 1 meter on axis
- 3 - Long term power handling capacity as defined in EIA - 426B test
- 4 - Calculated from rated noise power and sensitivity
- 5 - 1 kHz - 10 kHz average
- 6 - Recommended High-Pass (24 dB/Oct)

A full range of measurements, performance data, Ease™ and CLF Data can be downloaded from [www.atlasied.com](http://www.atlasied.com).

# FC-8T

## LOUDSPEAKER



### TECHNICAL DATA SHEET

### PERFORMANCE MEASUREMENTS

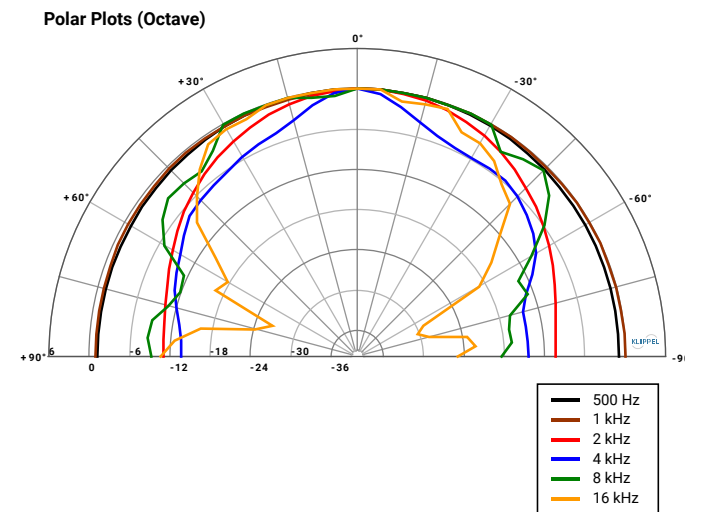
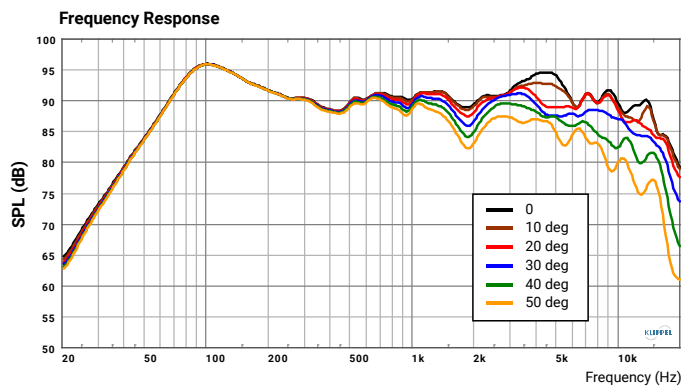
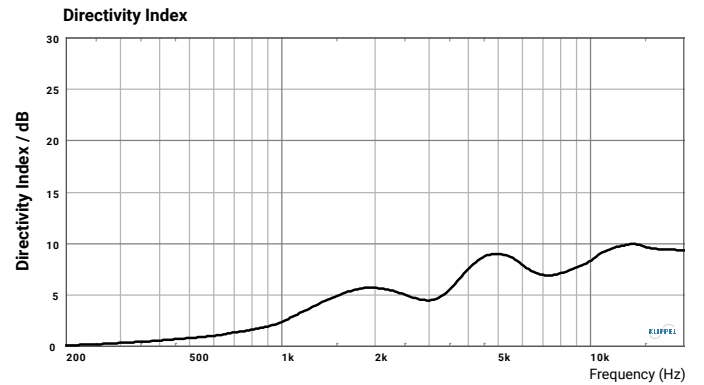
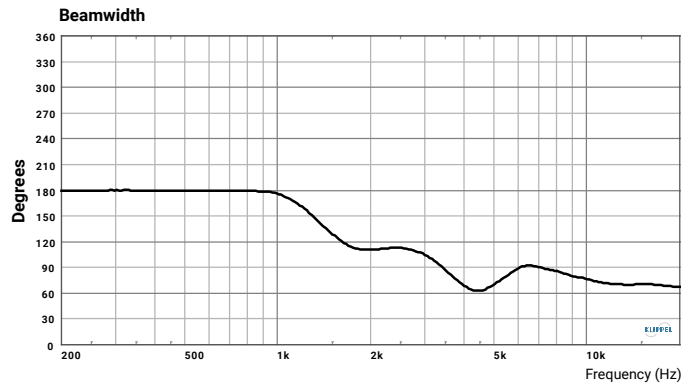
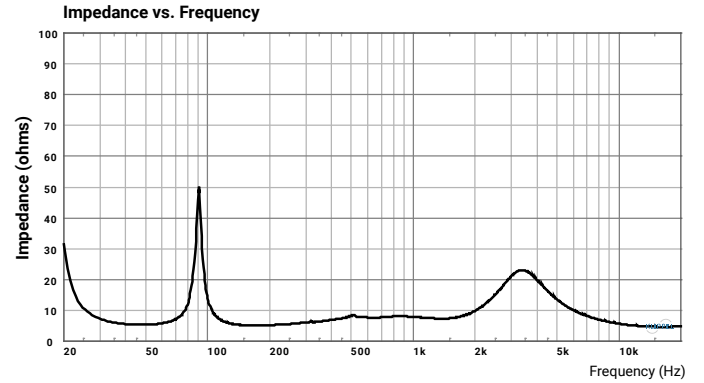
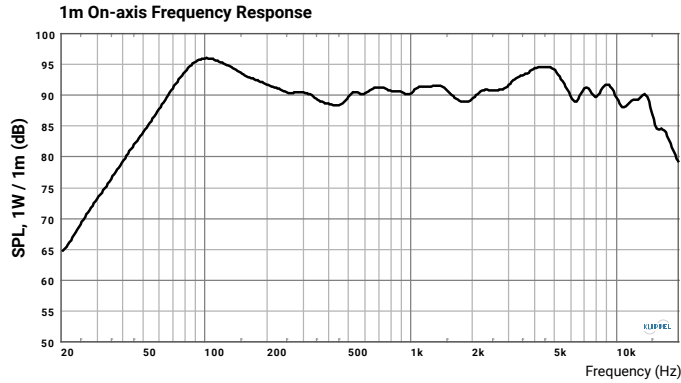

# FC-8T

## CEILING LOUDSPEAKER



### TECHNICAL DATA SHEET

#### DIMENSIONAL DRAWINGS

##### PRODUCT DIMENSIONS

Baffle Diameter	ø 12.75" (323.9 mm)
Back Can Diameter	ø 11.28" (286.5 mm)
Cutout Diameter	ø 11.57" (293.9 mm)
Mounting Depth	13.50" (343.0 mm)
Overall Depth	13.67" (347.1 mm)
Round Grille Diameter	ø 12.91" (328.0 mm)
Square Grille Length	12.91" (328.0 mm)

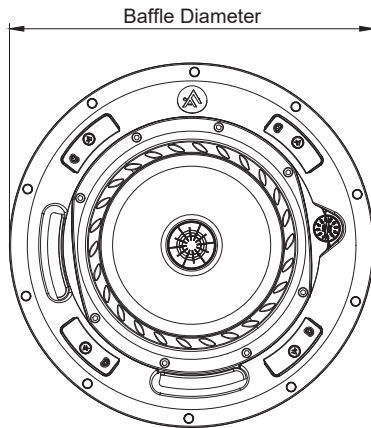

Front View

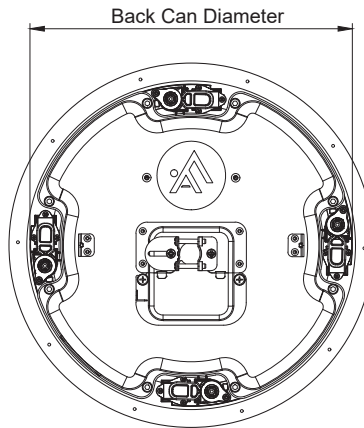

Rear View

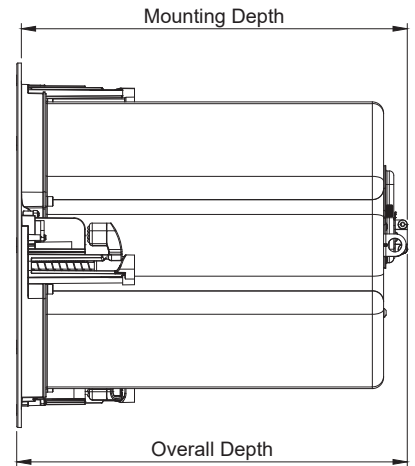

Side View

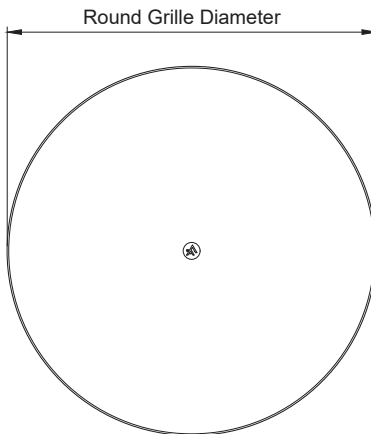

Round Grille

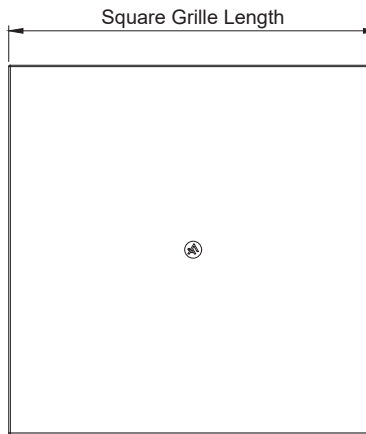

Square Grille

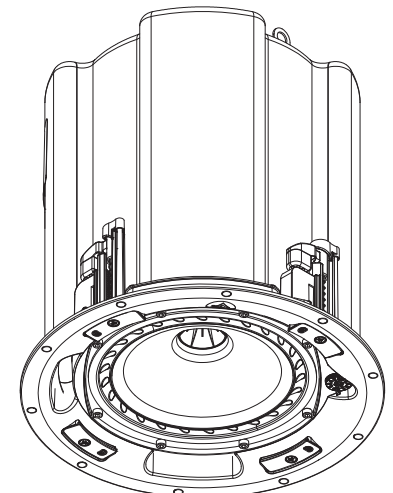

Isometric View

# FC-8T

## LOUDSPEAKER



### TECHNICAL DATA SHEET

#### ARCHITECT AND ENGINEER SPECS

The loudspeaker shall be of a two-way flush-mount design with an internal passive crossover and a 60 W low insertion loss 70/100 V transformer for use in constant voltage distributed lines. An 8-inch multi-fiber treated paper woofer with butyl rubber surround and 1" (25 mm) titanium dome with Ferrofluid cooled neodymium magnet system, shall be housed in a proprietary injection molded ABS UL94V-0, UV fade resistant vented baffle. The back can shall be of powder coated steel construction. A recessed termination box shall be integrated with the back can, a removable connector with screw terminals for secure wire termination with "loop through" facility shall be provided. Strain relief will be provided by a clamping mechanism for use with plenum rated cable or conduit. The loudspeaker shall incorporate a toolless, high-travel dog-leg mechanism. It shall utilize a one-piece, bezel-less grille and an optional square grille if required.

The loudspeaker shall comply with the following safety standards: UL1480A, UL2043, CE.

The loudspeaker shall meet the following performance specifications: On-axis system frequency range shall be 44 Hz to 30 kHz (-10 dB). The broadband sensitivity shall be 92 dB (2.83 V at 1 m) SPL in a full-space environment with recommended high-pass protection. The long-term power handling rating shall be 90 W as defined in EIA-426B. The maximum continuous output shall be 112 dB SPL and the maximum peak output shall be 118 dB SPL. The nominal coverage pattern shall be 90 degrees conical. The transformer shall have power taps at 60 W, 30 W, 15 W, 7.5 W (3.8 W, 70 V), plus an 8-ohm bypass, selectable using a rotary switch located on the front baffle. The loudspeaker Euroblock input connections shall allow for direct connection to 70-volt, 100-volt, or low-impedance amplifiers.

The loudspeaker grille diameter shall be 12.91" (328.0 mm), and 13.67" (347.1 mm) deep (to top of safety loop). The unit net weight shall be 17.2 lbs (7.8 kg).

Two support rails and one C-Ring shall be included.

The warranty shall be 5 years.

The loudspeaker shall be the Atlas + Fyne FC-8T.